



# ENABLING NH3 FUEL

Eddie's Law:  
*If anything can go right it will...  
...and at the best possible moment!*



**Sturman Industries**

Eddie Sturman

*"Leading the mechanical world into the Digital Age"*

Presented to  
2012 NH3 Conference, San Antonio, Texas  
October 1, 2012



# World Renewable Energy Forum – May 2012

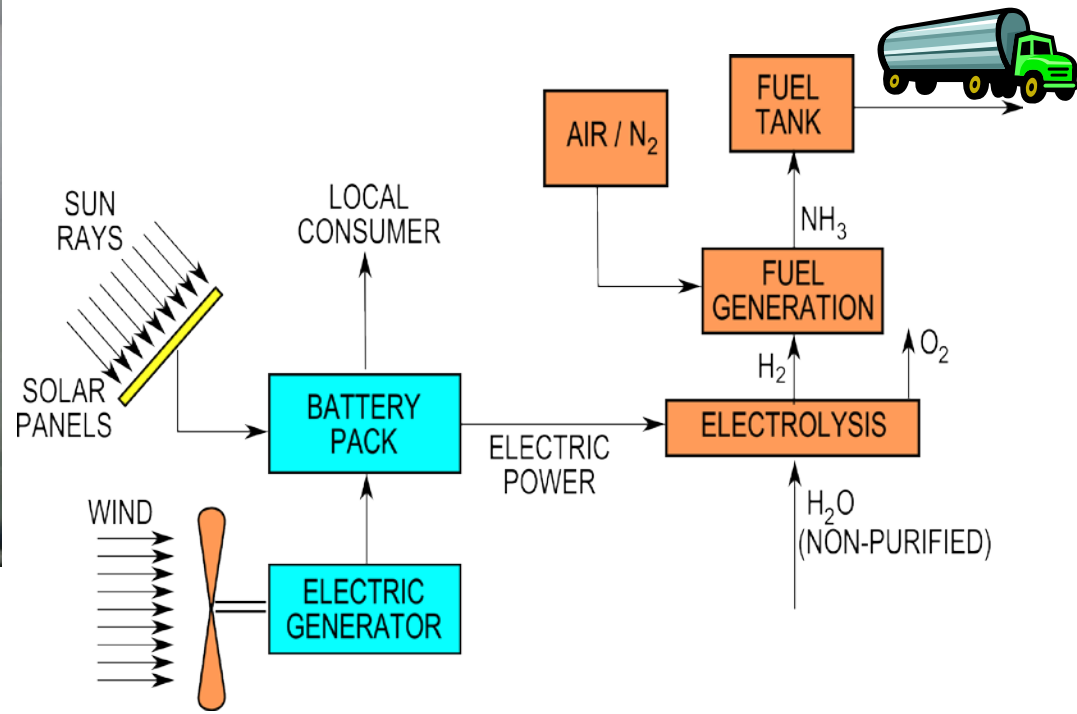

***Alternative fuels in conventional engines  
have a low probability of success***





**STURMANS WITH SECRETARY OF ENERGY  
DR. STEVEN CHU**

**Private Energy Roundtable  
WORLD RENEWABLE ENERGY FORUM  
Denver, Colorado – Summer 2012**





## AREDAY

Aspen, Summer 2012

AIR CONTROLLED  
ENGINE

*Optimizing 'How' We Use  
FIRE*

## Heavy Duty Trucking

Steve Sturgess - Article

*An ammonia fuel?  
Why not?*

## Colorado Rural Electric Innovation Summit

*Closing Plenary Session*

NH3 Micro Grids

*October 2011*

## Swedish American Sustainable Transportation

Washington D.C. – March 2012

**ALL-Ternative Engine**

## Table Talk

California Talk Radio

November 2011

*Any Fuel  
Any Size*



STURMAN 'ACE'

AIR CONTROLLED ENGINE

✓ OPTIMALLY EFFICIENT  
ENGINE COMBUSTION SYSTEM

✓ USES LIQUID OR GASEOUS FUELS

NH3 & NATURAL GAS  
INJECTOR OPTION

LIQUID FUEL  
INJECTOR OPTION



Engine  
Controller

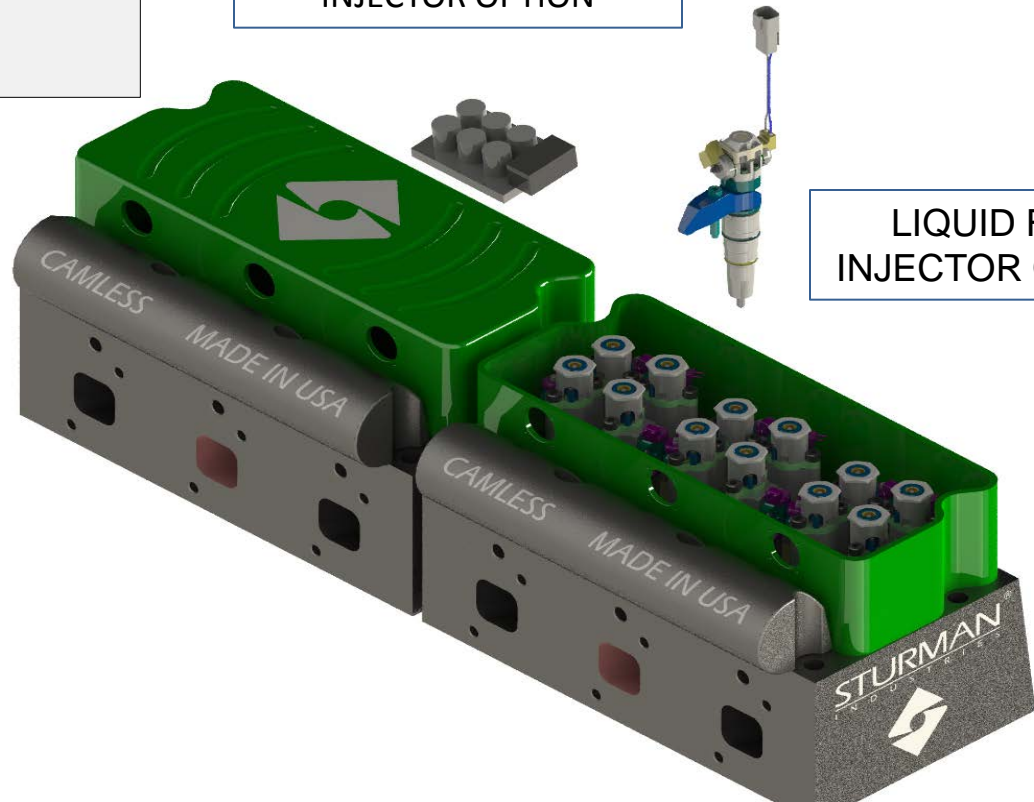



# DESTINATION

Wind



Sun



Waste or Fresh

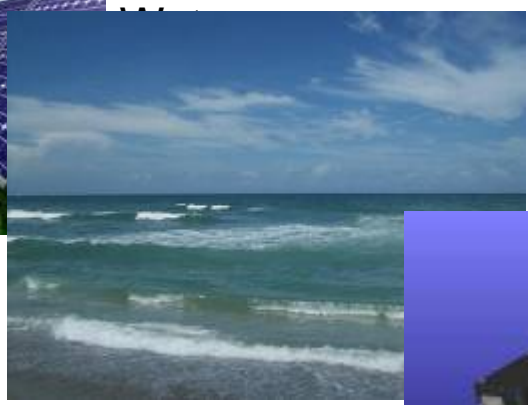

ADP<sub>t</sub><sup>TM</sup>

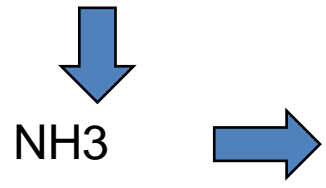

NH<sub>3</sub>





# Thank You

## Thank you for your attention

**For additional information of please contact**

Eddie Sturman at +1-719-686-6003  
[esturman@sturmanindustries.com](mailto:esturman@sturmanindustries.com)

[www.sturmanindustries.com](http://www.sturmanindustries.com)

